



B+S BLACK SERIES: UFWWSPD-1

Single Hole Deluxe Waterless Stock Pot

Project: _____ Item: _____



UFWWSPD-1

Standard Features:

- AISI 304 Grade Stainless Steel
- Heavy duty complete stainless steel frame
- Long skirt cast iron unflued ring - 340mm Diameter
- Heavy duty removable cast iron trivet
- Waterless feature eliminates the need for deck cooling
- One-piece machine pressed top deck - 1.5mm Thick
- Manually operated laundry arm and spindle
- Heavy duty stainless steel lever action gas control
- Flame failure fitted as standard
- Front waste gutter allows for greater ease in cleaning
- Waste shovel included
- Front access to all components makes service easy
- 24 Month Warranty

Options:

- Natural or LP Gas
- 24 Jet Mongolian Chimney Burner (CB)
- 18 Jet Duckbill Burner (DB)
- B&S Stock Pot with release valve - 170L (600 dia x 600 H)

Specifications:

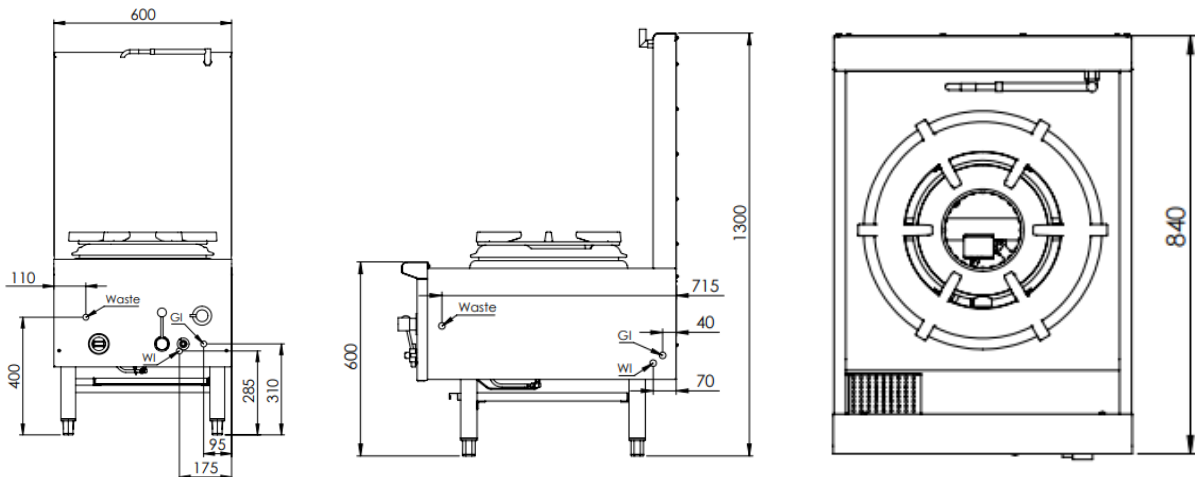

MODEL	LENGTH (mm)	DEPTH (mm)	HEIGHT (mm)	GAS CONSUMPTION (MJ/h)			
				NG - CB	NG - DB	LPG - CB	LPG - DB
UFWWSPD-1	600	840	1300	105	126	75	90

Connections:

GAS (GI) (BSP)	WATER (WI)	WASTE	SUPPLY PRESSURE (kPa)	
			NG	LPG
¾" (M)	½" (Copper)	2" BSP (M)	1.0	2.6

- Regulator is included within the unit
- **Must** be installed by an authorised installer in accordance to **AS/NZS5601.01**

Due to ongoing Product Development, Product Improvement and Research, B+S Commercial Kitchens reserves the right to alter specification without notice.

Approval Number: GMK 10701



B+S Commercial Kitchens
 57 Plateau Road Reservoir VIC 3073 Australia | +61 3 9469 4754
 info@bscommercialkitchens.com | www.bscommercialkitchens.com

