



K+ SERIES: DSK-3 Triple Deck Steamer

Project: _____ Item: _____



DSK-3

Standard Features:

- AISI Grade Stainless Steel
- Energy efficient heat exchange system
- Insulated heat exchange chamber
- Three jet burner system
- Flame Failure and Auto Ignition incorporated
- Auto refill system and pressure release Valve Installed
- Three stop rotary door lock system
- Front access to all components makes service easy
- XSENTIAL Water Filtration Included.
- QF9R Filtration System: QLD, NSW, ACT, VIC, TAS
- XP195R Filtration System: NT, SA, WA

Options:

- Natural or LPG Gas

Specifications:

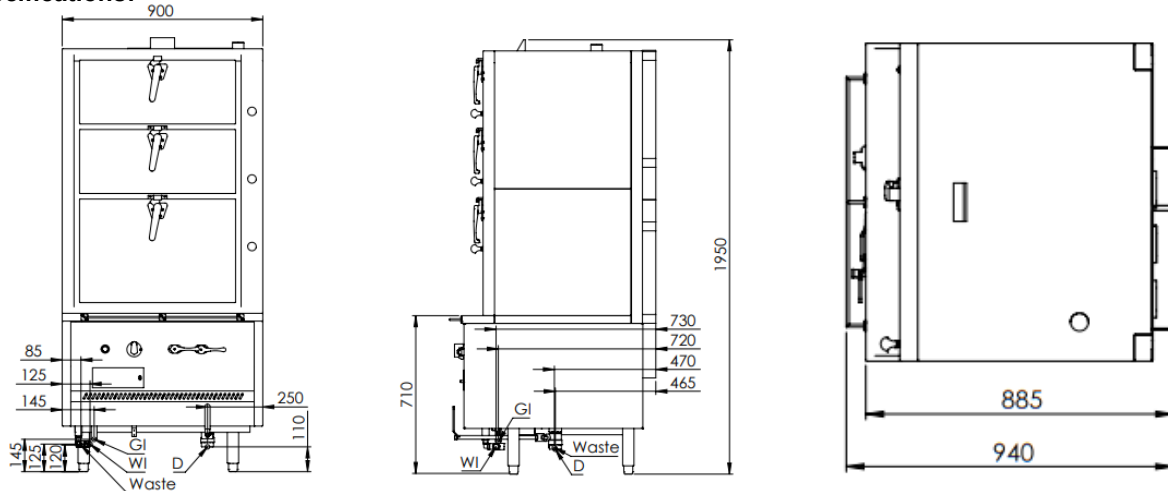

MODEL	LENGTH (mm)	DEPTH (mm)	HEIGHT (mm)	NET WEIGHT (kg)	GAS CONSUMPTION (Mj/h)	
					NG	LPG
DSK-3	900	885 (Body) 940 (w/Rail)	1950	-	150	150

Connections:

GAS (GI) (BSP)	WATER (WI)	WASTE (BSP)	TANK DRAIN (D) (BSP)	SUPPLY PRESSURE (kPa)	
				NG	LPG
3/4" (M)	Non-return isolating valve – 15mm (F)	2" (M)	2" (F)	1.0	2.6

- Gas regulator is included with the unit
- **Must** be installed by an authorised installer in accordance to **AS/NZS5601 refer to current version**
- Warranty **Voided** if Water Filtration device is not installed

Due to ongoing Product Development, Product Improvement and Research, B+S Commercial Kitchens reserves the right to alter specification without notice.

Approval Number: GMK 10677



B+S Commercial Kitchens
57 Plateau Road Reservoir VIC 3073 Australia | +61 3 9469 4754
info@bscommercialkitchens.com | www.bscommercialkitchens.com

